



Service Technicians Manual

GRAND PIANOS REGULATION

2008

Service Technicians Manual GRAND PIANOS REGULATION

1. General

1.1 Grand Pianos Storage Conditions at Shops and at Customers

Conditions of grand pianos storage at shops, at customers (in apartments), or possibly in recording studios would have to be identical. Grand pianos must be located a sufficient distance from the windows, from heaters, so that moisture occurring when the window are open and the radiating heat from heaters does not act directly on the instrument. Instruments are capable of fulfilling their function well in an environment where they are stored and used, providing that the temperature and humidity conditions pursuant to Table 1 are observed:

Table 1.

Environment temperature °C	Minimum relative air humidity %	Minimum absolute wood moisture %	Maximum relative air humidity %	Maximum absolute wood moisture %
10	30	6,6	55	10.7
15	31	6,5	56	10.6
20	32	6.5	28	10.7
25	34	6.5	60	10.8
30	35	6.5	62	10.8

1.2 Tuning of Grand Pianos

Tuning of grand pianos is performed according to the chamber A¹ frequency - 440Hz. Tuning using the small or large temperament is performed.

Table 2. Large temperament in the range D sharp - A¹

1	2	3	4	5	6	7	8	9	10
A ¹	A	E ¹	E	H	F sharp ¹	F sharp	C sharp ¹	G sharp ¹	G sharp
		3-1	4-2	5-3	6-2	7-5	8-6	9-3	10-8
						7-3	8-2	9-6	10-4
							4-2-8	5-3-9	10-6
11	12	13	14	15	16	17	18	19	
D sharp ¹	D sharp	A sharp	F ¹	F	C ¹	G ¹	G	D ¹	
11-9	12-10	13-11	14-1	15-13	15-2-16	16-3-17	18-16	2-19	
5-11	12-7	13-7	8-14	15-2	12-10-18	16-11-17	18-5	19-17	
5-7-11	12-8	13-8	10-8-14	15-10	16-14		12-18	19-6	
		13-9		15-11	10-16-9		18-13-11	18-5-19	
								15-13-19	

Table 3. Small temperament I in the range A - A¹

1	2	3	4	5	6	7	8	9	10	11	12	13
A ¹	A	E ¹	F	F sharp ¹	C sharp ¹	G sharp ¹	D sharp ¹	A sharp	F ¹	C ¹	G ¹	D ¹
	2-1	3-1	4-3	5-1	6-2	3-7	8-7	9-8	1-10	10-11	11-12	12-13
		3-2		5-2	2-6-3	6-7	8-4	6-9	9-10	2-10	1-3-10	13-2
						6-3-7	8-4-7	5-9-6	8-10-7	10-3		1-13
						4-3-7				1-10		
										1-10-1		

Table 4. Small temperament II in the range F - E¹

1	2	3	4	5	6	7	8	9	10	11	12	13
A ¹	A	D ¹	C	C ¹	F	A sharp	D sharp ¹	G sharp	C sharp ¹	F sharp ¹	H	E ¹
	2-1	3-1	5-4	6-5	1-6	7-8	8-1	13-9	10-2	11-1	2-13	13-1
		3-2	5-13	2-6	7-6	7-10	8-12	10-9	2-10-13	11-2		13-2
				6-13	10-6	11-7-10	8-12-1	10-13-9				
				1-6				12-13-9				

2. Grand Piano Regulation

2.1 Adjustment of the Key-frame-guide Adjusting Screw (balance-rail stud)

Key-frame-guide adjusting screw is adjusted using the tuning lever, without the action stack. There is a clearance between the key-bed (key-bottom) and the key-frame-guide adjusting screw head up to 0.1 mm.

2.2 Releasing (Easing) of the Key Bottom Holes

A properly released (eased) key, upon rising ca 1 cm above the balance-rail surface and upon dropping, must come (slide) down the balance-pin by action of its own weight (or possibly upon light tapping on the key), to its original position on the punching. However, at the same time the key must not show a clearance in the hole of the key bottom on the balance pin

(visible front-back movement on the balance pin). It must be possible to lightly slide the keys released in this manner out of the key frame pins and slide them back onto the key frame pins. Easing is performed using a special round reamer file for key balance holes.

2.3 Releasing (Easing) of Keys in the Key-chase (Key Button)

Between the balance pin and cashmere in the opening of the key-chase (button) of the key, there must be clearance on every side of 0.1 mm, meaning that upon light pressing of the key by the inner surface of the opening into the side towards the balance pin, clearance of 0.2 mm will arise on the opposite side between the balance pin and inner wall of the opening - Fig. 1.

The clearance is checked by leaning out the key into the sides, while the key is pushed lightly onto the balance rail using fingers of the other hand. When performing the check, the key is in its natural (basic) position. A qualified estimate is made of the clearance required.

In case the clearance is smaller, squeezing of the opening of the key-chase (button) must be performed for the balance pin. Easing is performed using special squeezing key bushing pliers with parallel working jaws with a small wing. Squeezing of the openings is performed always on both sides, so that pressing of the cashmere is uniform. Easing must be done carefully so that the keys are not too loose.

Figure 1 Clearance between the balance pin and the key cashmere

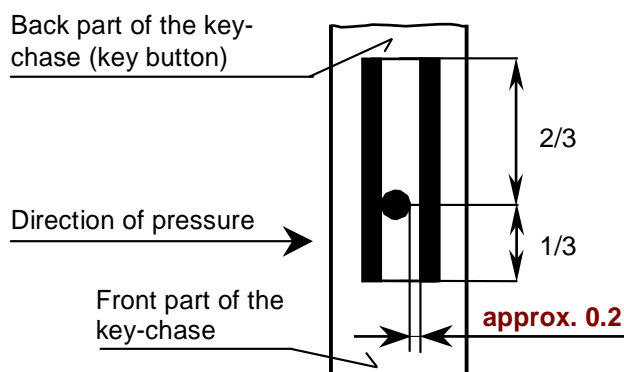

2.4 Releasing (Easing) of Keys on the Front Pins

Between the front pin and cashmere in the key bottom opening, there must be clearance of 0.25 mm on every side; meaning that in light pressing of the key by the inner surface of the opening into the side towards the front pin, clearance of 0.5 mm will arise on the opposite side between the front pin and inner wall of the opening - Fig. 2.

The clearance is checked by pressing down the front part of the key on the keyboard frame front rail so that it touch down on the felt punching of the front pin. The key is held at the place of the key button, grabbed by the key front, and by moving the key in its front part into the sides, the clearance of the front pin in the bottom opening of the key is checked. A qualified estimate is made of the clearance required.

In case the clearance is smaller, pressing out (squeezing) of the opening must be performed for the front pin. Releasing (easing) is performed using special pressing out key bushing pliers with parallel working jaws with a small wing. Pressing out of the openings is performed always on both sides, so that pressing of the cashmere is uniform. Releasing must be done carefully so that the keys are not too loose. Two released adjacent keys must not touch by their neighbouring, side surfaces ones upon their pressing towards each other. In openings for front pins of the keys pressed out (squeezed) too much (the clearance is greater than the tolerance prescribed), a repair is performed. Manual re-cashmerring of the opening is performed.

Figure 2 Clearance between the oval front pin and the key cashmere

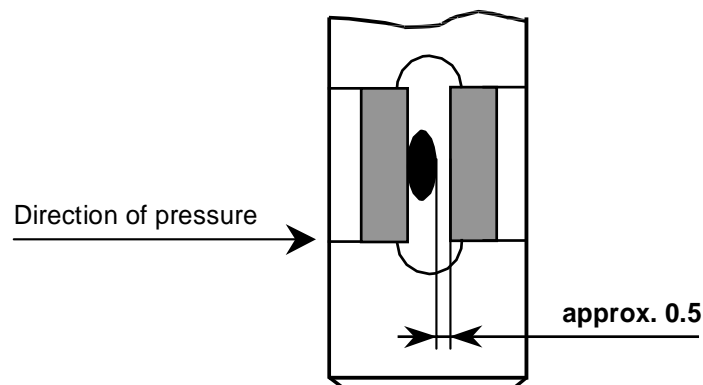

2.5 Positioning of Jacks under the Knuckles

Positioning of jacks under the knuckles is performed by the jack regulating screws. The back side of the jack must be situated approximately by 0.5 - 0.7 mm behind the back edge of the knuckle insert (strip), when the hammer shank is raised up ca 5 mm above the hammer rail - Fig. 3.

Figure 3

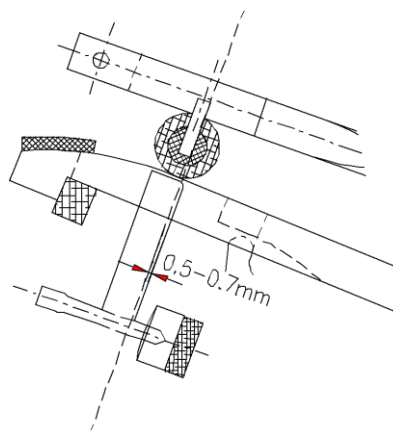

2.6 Clearance of the Jack in the Repetition Lever

Clearance of the jack in the repetition lever is adjusted by the repetition-lever regulating screw. The upper surface of the jack must be found 0.3 mm below the level of the upper surface of the repetition lever.

2.7 Clearance between the Jack and the Jack - pad Felt

Clearance between the jack and the jack pad felt during sliding of the jack from below the Knuckle should be 1 - 2 mm (in case of proper distance of the hammer-flange rail and wippen rail) - Fig. 4.

Figure 4

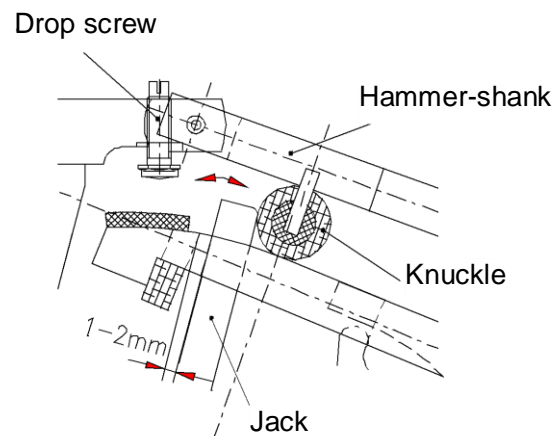

2.8 Keyboard Alignment

Alignment of white keys to a level is performed by underlying of the keys with paper washers on the balance rail pins using a long, light, flat ruler. There must be the minimum space of 17.5 mm between the bottom surface of the key and the key frame. Distance of the upper key surface in the front part of keys from the key bed should be the same on both sides (in the bass as well as in descant section).

2.9 Alignment of Black Keys

Alignment of sharps to a level is performed by underlying of the black keys with paper washers on the balance rail pins. Distance of the upper surface of the black keys above the white keys top surface shall be 12.3 mm.

2.10 Hammer-blow Distance

Distance of hammer heads from the strings (Hammer-blow distance) is set by adjusting the capstan screws. The distance required is 45 mm - Fig. 5.

Figure 5

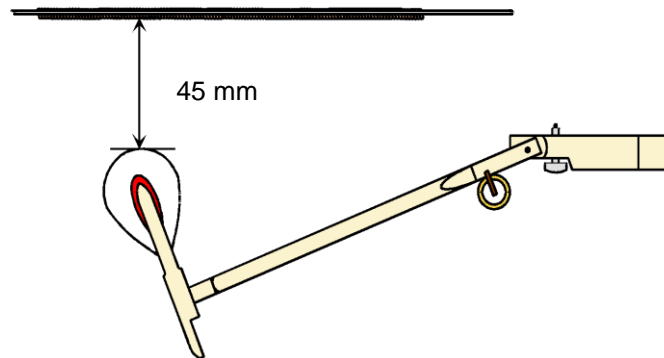

2.11 Dip of White Keys

Upon pressing the white key onto the front rail washers (punchings), the height distance of its upper surface and the upper surface of the adjacent key is 10 mm + 0.5 mm. The correct dip is achieved by underlying of front rail felt washers with paper washers. When underlying the keys to achieve the dip desired, a special gauge is applied - Fig. 6.

Figure 6

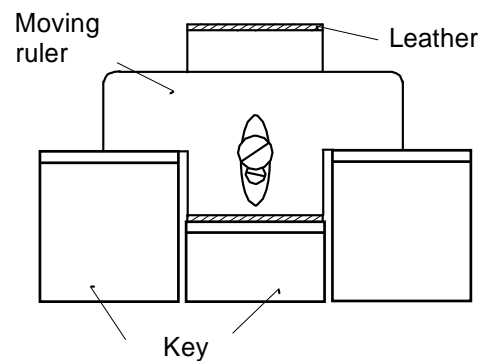

2.12 Let-off of Hammers from the Strings

Let-off (let-off) represents the distance of the hammer head top from the string to which the hammer rises upon pressing the given key, in the moment the jack bears against the set-off dolly (regulating button) and slides out from the knuckle. Let-off is adjusted by turning the set-off dolly (regulating button). Set-off of the hammers from the strings shall be 3 mm in the bass section, in the middle section it passes continuously to 2 mm, and in the descant section to 1.5 mm.

After touch 1 mm to the down position must be felt on the key upon the let-off the hammer.

2.13 Dip of Black Keys (Sharps)

The dip is achieved by underlying of front rail felt washers on front rail oval pins with paper washers so that the same feeling of the final depressing is achieved as in case of white keys.

2.14 Check (Back Check) Regulating

The checks (back checks) position and regulating is performed without using any instruments, only by hand-bending the checks. When the checks height and position of the checks towards the hammer mouldings are correct, the hammers are captured in the distance of 16 mm from the strings (distance between the hammer head top and the string). The hammer mouldings are to be captured in 1/4 to 1/3 of the check-felt length - Fig. 7.

Figure 7

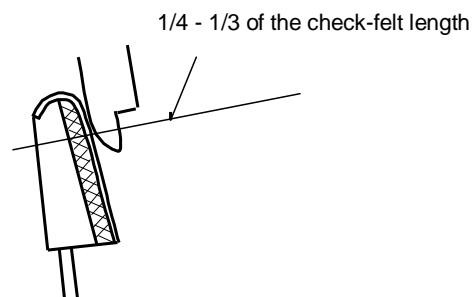

2.15 Adjustment of Repetition Springs

The repetition spring is adjusted using a special spring regulating hook - Fig. 10. The spring shape is adjusted, using the hook, so that it is strained (pre-stressed) or slackened - Fig. 9. In some actions, a regulating screw is used, using which the springs pre-stress is set - Fig. 8. The springs adjustment is checked as follows. The key is pressed completely so that the hammer is captured by the back check. Then the key is released slightly which causes releasing of the hammer moulding captured by the back check. This hammer then rises by ca 8 - 10 mm. When the spring pre-stress is correct, the hammer rises quickly in a nimble manner but not much wildly (vehemently), without jerking.

When the spring is not strained (pre-stressed) sufficiently, the hammer rises sluggishly (lazily) and slowly or it does not rise at all. When the spring is strained (pre-stressed) too much, the hammer rises very vehemently.

Figure 8 Repetition lever with the repetition-spring-regulating-screw

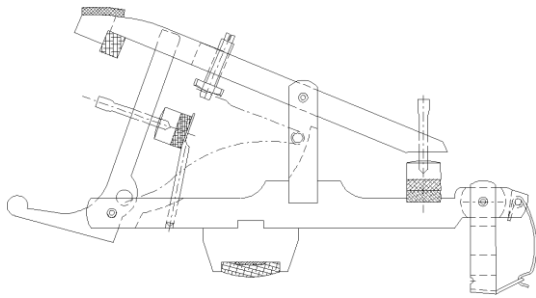

Figure 9 Repetition lever without the repetition-spring-regulating-screw

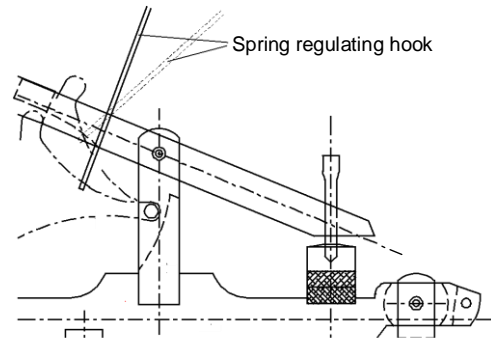
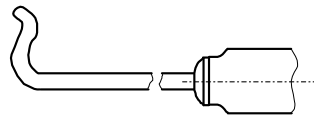

Figure 10 Spring regulating hook



2.16 Drop Adjustment

The drop is adjusted by turning the drop-screw. Drop screw in the hammer flange is unscrewed partially, namely regulated in such a manner so that upon let-off of the hammer from the strings, the hammer drops by 3 mm in the bass section, by 2 mm in the middle section and by 1 mm in the descant section. The drop movement must be fast and definite (exact).

2.17 Damper Adjustment

Damper motion is adjusted by bending the damper-spoon. The spoon is bended closely at the damper-lever, using flat nose pliers with long jaws or using a special bent fork-type action regulator. The spoons are adjusted so that upon pressing a white key, the damper begins to lift in the moment when the hammer is in one half of its way to the strings.

2.18 Damper Straight Run Adjustment

Check and adjust straight uplift of dampers. When action is taken out push gently right pedal several times, watch the straightness of damper's run. Clearances between dampers must not change, dampers must not turn. Adjust it by turning dampers wires by flat pliers.

2.19 Damper Synchronous Run Adjustment

When action is taken out push gently right pedal several times, watch the synchronous run (damper lift) of dampers. Adjust the differences by turning damper lever adjusting screws. Late reaction – screw out, early reaction – screw in.

2.20 Damper-check (Stop Rail) Adjustment

The damper-check is adjusted vertically so that the damper stroke (uplift) is sufficient, and so that there is a space of 2 to 3 mm between the risen damper-lever and the stop rail (damper check).

Release the screws of damper stop rail a little. Adjust stop rail vertically so that damper liftup is sufficient and between lifted damper lever and stop rail are 2 – 3 mm.

2.21 Damper Pedal adjustment According

Adjust right pedal vertical run by adjustment of two adjusting screws in sostenuto lever under key bed.

2.22 Prolongement function Adjustment

Function:

Push right pedal, dampers lift up. Push middle pedal, release right pedal, all the dampers must remain lifted. Release middle pedal, all the dampers must fall down freely on strings.

Adjustment:

Push middle pedal several times, watch the prolongement brass rod. It must turn freely without lifting up the dampers. Adjustment can be done by vertical and front-to-back positioning of prolongement rod. Vertical positioning can be done when you release fastening screws with cross head. Front-to-back positioning can be done by turning hexagonal fastening screws of prolongement rod.

2.23 Balancing of the Keyboard

The key is supported with one's finger, touching the bottom front edge of key in the normal position. The weight (50 - 55 g, see the chart bellow) is placed onto the front edge of white key, aligned with the front edge of key - Fig. 21. In sharp keys, the weight is placed to be aligned with the front edge of the upper surface of the sharps. Upon releasing the key, the key loaded with a weight (50 - 55 g, with tolerance of $\pm 1g$) and key-lead placed at sides of the keys must overbalance barely so that the key goes down smoothly and the hammer rises continuously up to the position when final pressure resistance is felt on the key 1 mm from the key down position.

When the given key is balanced properly, then upon its pressing to the final pressure resistance position 1 mm from the down position, being loaded with a 22 g weight, and upon its releasing, the key must return up lively to its original position. The keyboard is balanced together with the action, removed from the instrument.

Adjustment of the balance is performed by placing key-leads, of the mass 16 g into white keys and 13 g into black keys (sharps). The balancing key-leads are located between the balance pins and the front-rail oval pins so that the drilled-in holes centres for key-leads are located at least 15 mm from holes for these pins. The distance between the centres of individual balancing key-leads shall be 25 mm at least - Fig. 11. When it is necessary to drill behind the balance pin, again, the centre of the first key-lead is located at least 15 mm from the opening for balance pin or from the capstan screw.

Figure 11 Placement of the weight and minimum distances of the balancing leads

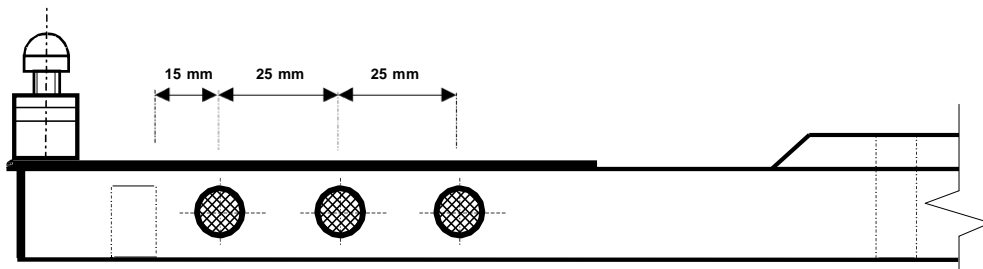

Standard balancing - Balancing is performed using the weight of 51 g.

German balancing - Balancing is performed using weights from 55 g in the bass section to 50 g in the descant section, according to the table.

Keys order	1 - 27	28 - 40	41 - 53	54 - 67	68 - 88
Weight mass	55 g	53 g	52 g	51 g	50 g

2.24 Fasten Key Stop Rail back above the keys.

There must be clearance of 1 – 2 mm between the rail and keys.

3. Voicing verification

3.1 Hammer Right-Left Positioning.

Push all the keys, watch their right-left position on strings. Hammers of more-string tones have to be positioned a little right, because of movement of action (not to contact left string when pushing left pedal). Bass single strings have to be in centre of hammers. Adjust hammers position by gentle aside turning of hammer flanges by special tool.

3.2 Side Movement of Action.

Push left pedal, hammers of two string tones must play only one string. Hammers of three string tones must play only two strings. Hammers of single bass tones must contact the string a little aside the centre of hammer, but not on hammer's edge. Adjustment of action movement can be done by turning the regulating screw in right edge of key frame. This screw stops the action in the right moment, contacting the right key block.

3.3 Hammer Positioning on Strings.

Check the right contact of hammers on more-string tones. Lift up the hammer shank by special hook, push the hammer gently to strings, push right pedal (dampers up). Twang by plectrum the strings of one tone separately, none of them can play. If some of them sounds, sand the hammer under other strings of this tone carefully.

3.4 Voicing Verification.

Play separated sections repeatedly, look for tones with different colour of tone, mark this tone. Stick the hammers of too sharp tone by voicing needles. Modify needling techniques according to required tone change. For example make the first deep stitch by single needle to sides of hammer or to it's arms. Then make only gentle stitches to arms of hammer by single or three needle tool. Check the tone when you press left pedal. Unify the different tones by additional needling. Then brush the hammers by brass brush in the end.



Paul Rea

National Service Manager

Petrof USA, LLC

5400 Lawrenceville Highway

Suite B1&2

Lilburn GA 30047

Office: 404-680-6872

Fax: 866-438-2603

service@petrofpianosusa.com

www.petrofpianosusa.com